



LGT-401L

Yamaha Drive2

LED Light Kit with RGBW Accent Lights

Installation Instructions



Caution: Please read through the instructions carefully. The included lights and light kit wire harness are designed for 12-48V operation only. Operating this kit at a higher voltage will void any and all warranties. **Optional add-on accessories and those sold as part of a Build Your Own Kit for this light kit may not be rated for any voltage over 12V DC and can be damaged if installed at a higher voltage.** A voltage reducer (sold separately) is recommended when installing 12V accessories to avoid damage.

Before starting this project, remove the system's positive and negative connections from the battery or battery pack. Look behind each drill location **BEFORE YOU DRILL**. Installer is responsible for damage (i.e. drilling into a wiring harness, battery, fuel tank etc.).

Table of Contents

| | |
|---|----|
| Wire Harness Overview | 3 |
| Before You Start | 4 |
| Headlight & Taillight Preparation | 4 |
| Wire Harness Installation | 5 |
| Accent Lighting Options | 7 |
| Single Color Accent Lighting (Out of the Box) | |
| 2 Color Combination Accent Lighting | |
| Multi-Color Combination Accent Lighting (LGT-332 Controller Required) | |
| Independent ON/OFF Toggle Switch for Accent Lighting (LGT-331 Required) | |
| Headlight Installation | 9 |
| Taillight Installation | 10 |
| Power Connections | 10 |
| Turn Signal Assemblies | 11 |
| LGT-T1 (LGT-143A) Basic Turn Signal | |
| LGT-T2 (LGT-112) Standard Turn Signal | |
| LGT-T3 (LGT-132A) Deluxe Turn Signal | |
| Horns | 13 |
| Horn Only (For use with LGT-T2 and LGT-T3 Turn Signals) | |
| Horn w/ Horn Button (For use alone or with LGT-T1 Turn Signal) | |
| 12 Volt Receptacle and Dual USB Outlets | 14 |
| ACC-0058 12 Volt Outlet | |
| ACC-0097 Dual USB Outlet 12-48V | |
| Brake Light Switches | 15 |
| LGT-B1 (LGT-138) Brake Pad Light Switch, Universal Fit | |
| LGT-B12 Brake Switch with Time Delay | |
| LGT-B13 Brake Pad Light Switch, Yamaha Drive2 17-19 | |
| LGT-B14 Brake Pad Light Switch, Yamaha Drive2 20+ | |

Tools Needed for Installation

- Screwdriver (Phillips & Flat Head)
- Sockets & Open Ended Wrenches (7/16", 1/2", #3 Allen Hex)
- Drill, Drill Bits & Hole Saws (1/8", 3/16", 7/32", 1/4", 5/8", 3/4", 7/16", 1", 1-1/8)
- Rivet Gun
- Rivet Removal Tool
- Jig Saw or Rotary Tool
- Sandpaper or File
- Painter's Tape or Masking Tape
- Marking Device
- Utility Knife
- Safety Glasses

Wire Harness Overview

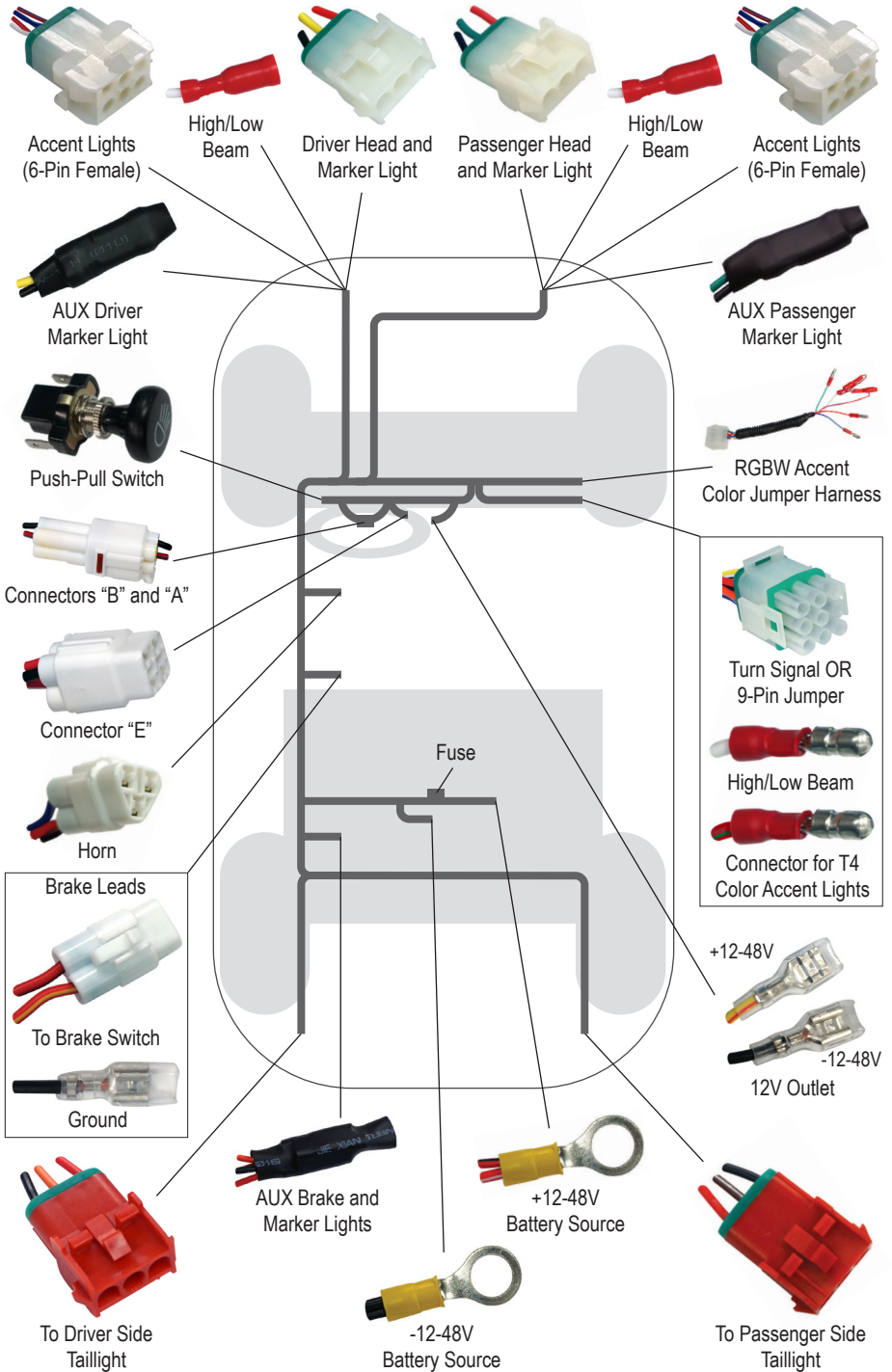

Before You Start

1. Turn Key OFF.
2. Place Tow/Run Switch in Tow if equipped.
3. Remove the system's positive and negative connections from the battery/battery pack.
4. Engage the parking brake.

Headlight & Taillight Preparation

Headlight Preparation

1. Cut out the headlight template following the guidelines.
2. Place the template on the driver side front cowl and align it with the cowl mold lines and bottom edge of the cowl. Secure with painter's tape.
3. Trace the inside contour of the template using a marking device.

NOTE: To prevent chipped paint on a painted cowl, tape over the drawn line and redraw over the tape using the template.

4. Using a jig saw or rotary tool, cut out the **INSIDE** of the marked area. Test fit the headlight and make any adjustments before removing the tape. Once the light fits, remove the tape and sand any rough edges.
5. Flip the template over and repeat Steps 2-4 for the passenger side.

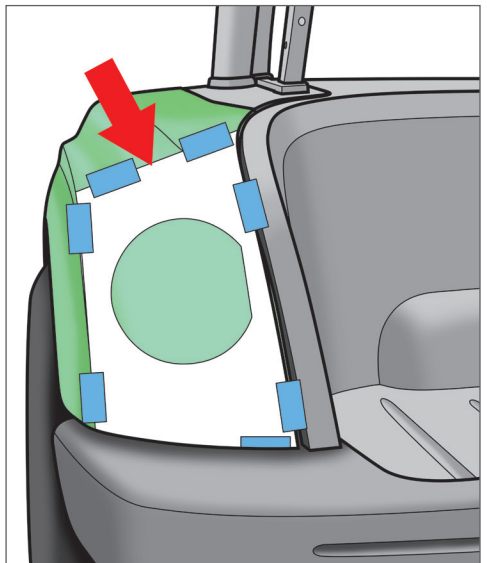
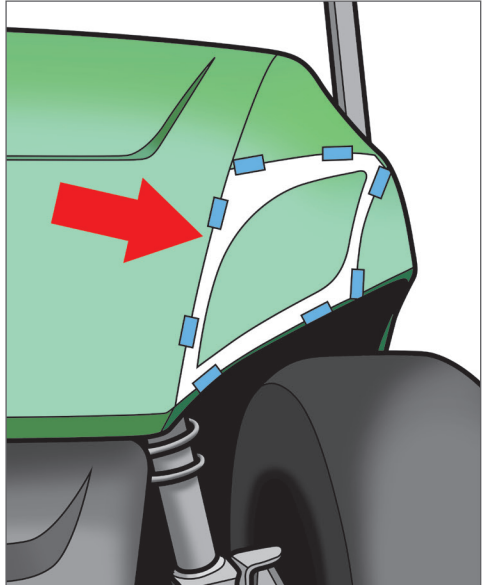

Taillight Preparation

1. Cut out the taillight template following the guidelines.
2. Place the template on the driver side rear body and align it with the body lines and edge of the rear body. Secure the template with painter's tape.
3. Trace the inside contour of the template using a marking device.

NOTE: To prevent chipped paint on a painted body, tape over the drawn line and redraw over the tape using the template.

- Using a jig saw or rotary tool, cut out the INSIDE of the marked area. Test fit the tail-light and make any adjustments before removing the tape. Once the light fits, remove the tape and sand any rough edges.
- Flip the template over and repeat Steps 2-4 for the passenger side.

Wire Harness Installation

- Lay the harness parallel to the driver side of the cart to help with orientation of the harness before installation.
- Disconnect the fuse holders from each other.

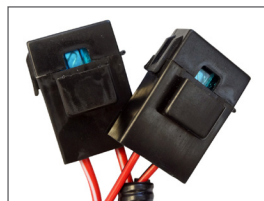

- From underneath the driver side of the cart, gently run the battery connections and fuses into the battery compartment. Make sure the leads can reach the appropriate terminals. Set the leads to the side and away from the terminals.

NOTE: Leads will be connected after completing the installation of the harness, lights and/or accessories.

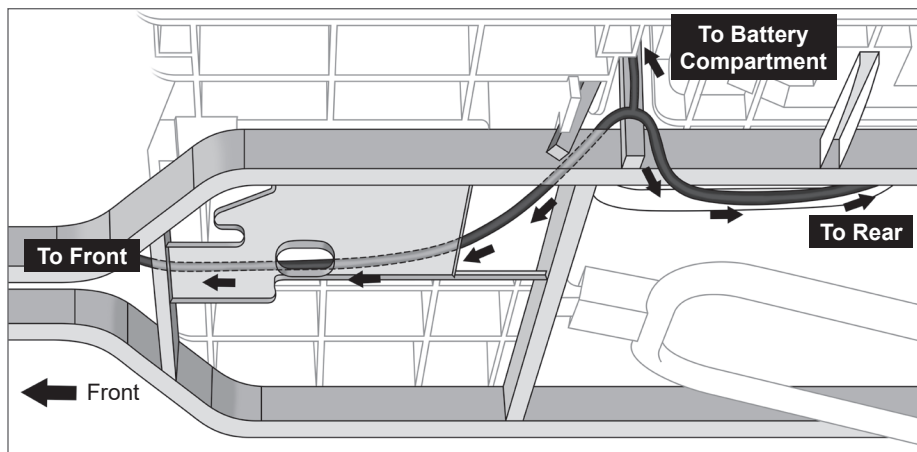

- Feed the rear portion of the harness through the cart so the taillight connections reach the holes in the rear body. The harness can be run parallel with the cart's harness for a cleaner installation.

The shorter cable will rest on the top of the driver side wheel well.

Route the longer cable behind the battery compartment and over the passenger side wheel well.

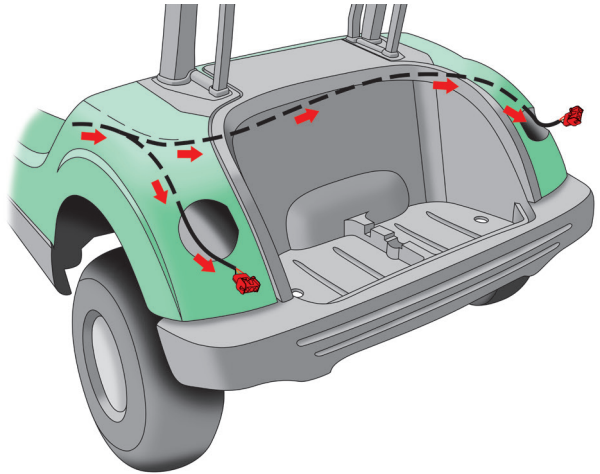

- 5. Make sure the taillight leads reach the holes in the rear body. Once the leads are in position, use cable ties to secure the harness in place and away from any moving parts or areas where it can be pinched.
- 6. Carefully remove the dash insert (cup holder area) from the dash. Retain hardware.

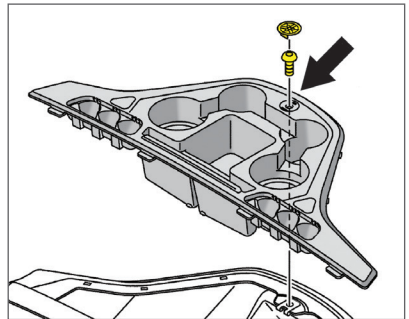

- 7. Run the front portion of the harness over the cross member in the frame and towards the front of the cart.

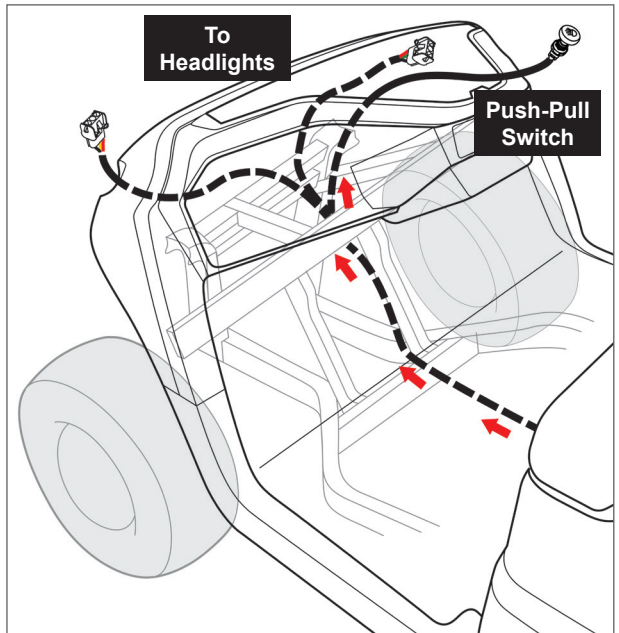

- 8. Once the harness is through the opening, run the driver and passenger headlight connectors up and over the front suspension and towards the openings in the front cowl.
- 9. Route the push-pull switch and other leads up and into the cup holder area.

- Once the harness is in place, use cable ties to secure the harness to the underside of the cart and away from any moving parts or pinch points. If not installing the horn or brakes, secure the leads with the rest of the harness.
- Configure the jumper harness on the turn signal connector:

If installing a turn signal, remove the jumper from the 9-pin connector. Retain jumper.

If installing brakes without a turn signal, switch the (2) male 2-pin connectors. Leave the jumper harness connected to the 9-pin connector.



Push-Pull Switch Installation

NOTE: If installing the LGT-132A (T3), LGT-180 (T4) or LGT-137 (T5) turn signal switches or a key switch with ON/OFF light capability, do NOT install the push-pull switch.

- If powering the lights with a push-pull switch, find a convenient location on the dash to mount the push-pull switch. Mark the center of the mounting location with a marking device.
- Carefully drill a 7/16" hole at the marked location. File any rough edges.
- Remove the knob, retaining nuts and lock washer from the push-pull switch and insert the shaft of the switch into the newly drilled hole.
- Secure using the lock washer and retaining nuts. Reattach knob.

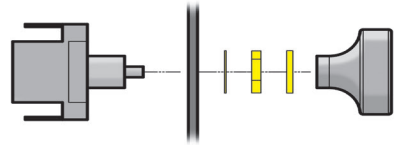

Accent Lighting Options

Single Color Accent Lighting (Out of the Box)

- For WHITE accent lighting only, configure the plug & play harness as shown. Cover the un-used male bullet connectors with electrical tape to protect them.

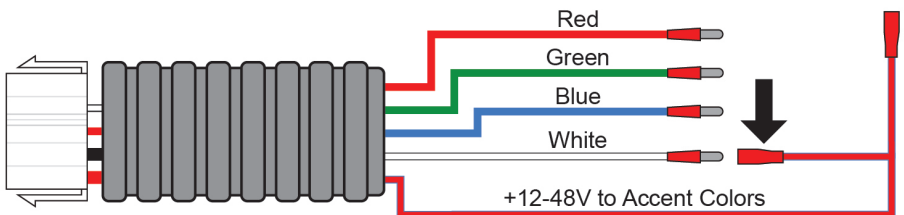

Accent Colors from Plug & Play Harness

2. For RED, GREEN or BLUE accent lights, switch the WHITE color wire with either of the three different RGB color wires (RED, GREEN or BLUE) shown on Page 7.

Cover the un-used male bullet connectors with electrical tape to protect them.

2 Color Combination Accent Lighting

1. For two color combination accent lighting, connect the (2) female bullet connectors to any (2) of the RGBW color wires (RED, GREEN, BLUE or WHITE) for a single combined color (i.e. RED + BLUE = PURPLE). See diagram on Page 10.

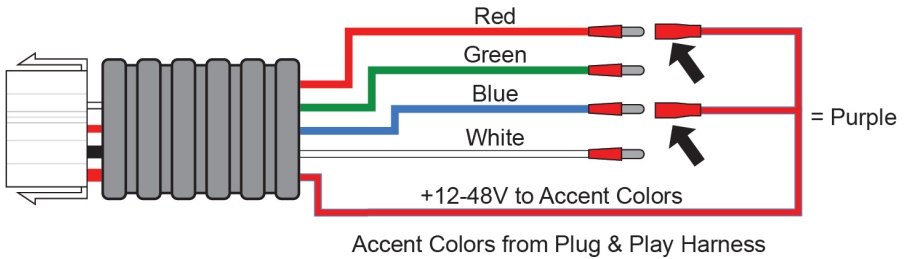

2. Cover the un-used male bullet connectors with electrical tape to protect them.

Multi-Color Combination Accent Lighting (LGT-332 Controller Required)

1. Remove the RGBW jumper harness from the plug & play harness and replace it with the LGT-332 Wireless Controller.

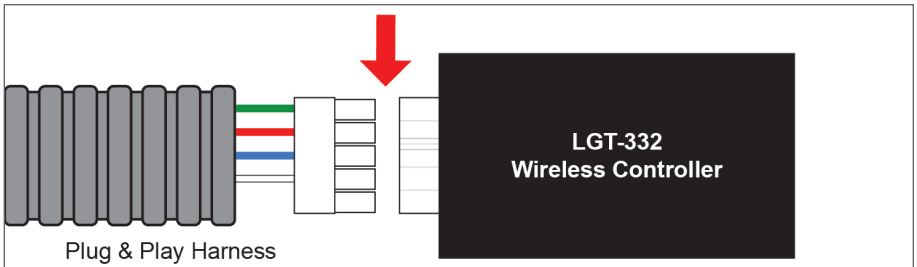

2. Scan the QR code on the controller to download the app to a smart device.
3. Once downloaded, enable Bluetooth® on your smart device. Connect the App to the LGT-332 controller per the device's Bluetooth® instructions.

Independent ON/OFF Toggle Switch for Accent Lighting (LGT-331 Required)

1. Locate connectors "A" and "B" near the push-pull switch and separate them.
2. Connect the ON/OFF toggle switch between the connectors "A" and "B".

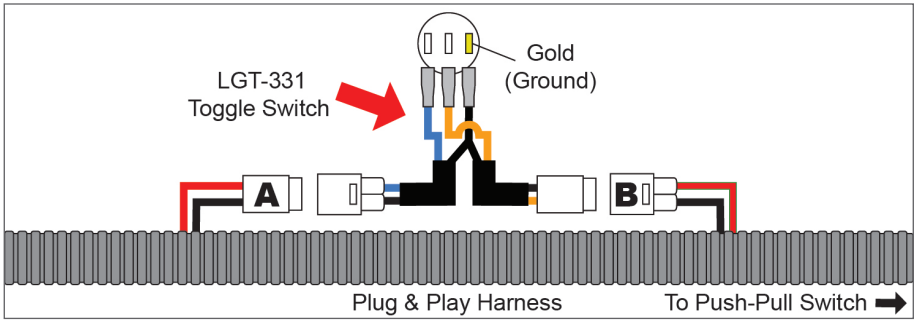

3. Find a convenient location on the dash to mount the toggle switch. Mark the center of the mounting location with a marking device.
4. Drill a 3/4" hole at the marked location. File any rough edges. Use a small file to make a small notch on the left side of the mounting hole. This notch will align with the raised line on the left side of the toggle switch to prevent the switch from rotating.
5. Disconnect the wires from the toggle switch and insert the switch in the newly drilled hole. Reconnect the leads to the toggle switch as shown.

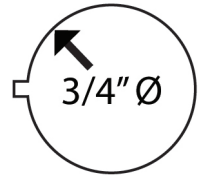

Headlight Installation

1. Connect the driver side headlight to the driver side headlight 3-pin connector and the 6-pin accent lights connector.
2. HIGH / LOW Beam Function: High/low beams can be controlled by the T3, T4 or T5 turn signal switches OR the LGT-169 high / low beam switch. If installing a T3, T4 or T5 turn signal with high low beam capabilities, connect the bullet connectors on the headlights to the bullet connectors on the plug & play harness to enable the low beam option.
3. Install the headlight using the Included Mounting Screws.

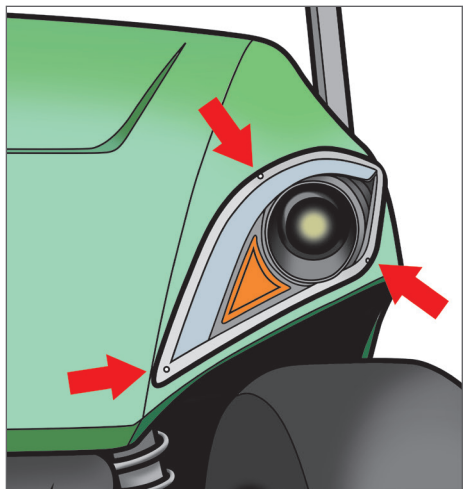

4. Repeat for the passenger headlight.
5. For Headlights Only (No Brake or Turn Signal Switch): Configure the jumper harness on the 9-pin turn signal connector so the connector labeled "Connector Used for Running Lights Only" is plugged into the 2-pin female connector next to it.

Taillight Installation

1. Connect the driver side taillight to the driver side taillight lead that was pulled through the hole in the rear body.
2. Install the taillight using the [Mounting Screws](#).
3. Repeat for the passenger taillight.

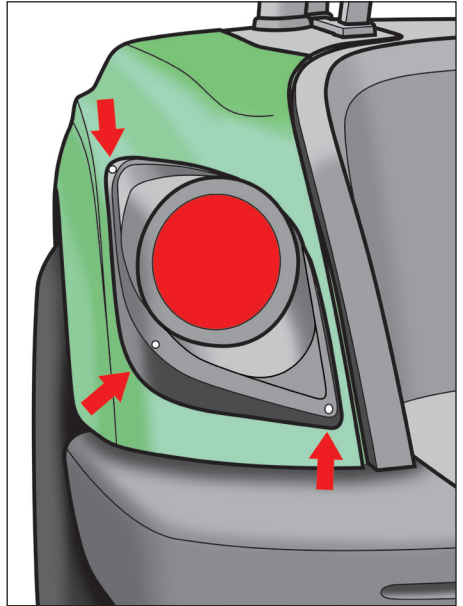

Power Connections

NOTE: Complete this section once all lights and optional accessories have been installed. The following diagram shows the batteries in factory configuration. Each configuration may vary. Test all batteries with a voltage meter prior to installation to determine the output voltage.

CAUTION: This light kit is designed to operate at a DC voltage range of 12-48V. Please be advised that add-on accessories and those sold as part of a Build Your Own Kit for this light kit may not be rated for any voltage over 12V DC and can be damaged if installed at a higher voltage. A voltage reducer (sold separately) is required when installing optional 12V accessories to a power source greater than 12V DC.

CAUTION: Installer must use extreme caution when connecting accessories to DC voltage. Improperly installing accessories to DC voltage of 12-48 Volts may lead to serious injury. We highly recommend professional installation for any accessory operating at a DC voltage greater than 12 Volts.

1. Verify the cart is in the TOW position (if equipped) and the key is OFF.
2. Verify any exposed wires and the push-pull switch are not touching the frame or any metal parts on the cart.
3. Connect the positive and negative battery connections from the light kit's harness to the batteries. Tighten the nuts but do not over tighten. Over tightening can destroy the battery posts.

Gas Carts: Connect the wires to a 12V battery.

48V Electric Carts with 8V Batteries for 12V Output: A voltage reducer is required to reduce the voltage to 12V. This is the safest option if installing optional accessories.

48V Electric Carts with 8V Batteries for 48V Output: This option is not recommended if installing optional accessories.

NOTE: Light sparks can be normal when connecting batteries, but a bright arching flash indicates there is a short in the system. The diagram below shows the batteries in factory configuration. Always test the batteries with a voltage meter as each configuration may vary.

48V Drive2 with 8 Volt Batteries

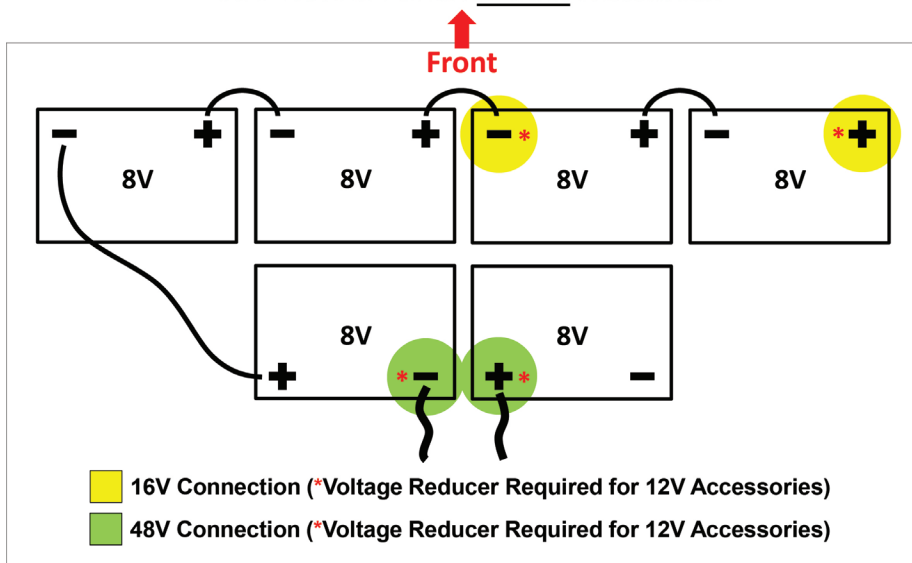

- Put the cart in the RUN position and turn the key ON.
- Turn the lights ON and test the lights and accessories to make sure they function properly.
- Secure any loose wires with cable ties.

Turn Signal Assemblies



LGT-107A



LGT-T1



LGT-T2



LGT-T3

NOTE: If installing a steering column cover, do so before installing the turn signal. See individual instructions for LGT-180 (T4) and LGT-137 (T5) turn signal assemblies.

1. Mount the turn signal assembly in a convenient location on the steering column using the Included Hardware.

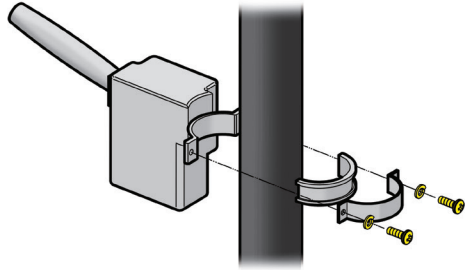

2. Peel back the rubber boot at the base of the steering column.

3. Use a utility knife or other cutting device to carefully cut a small notch on the left side of the rubber boot, next to the steering column. The notch should be large enough to accommodate the turn signal harness.

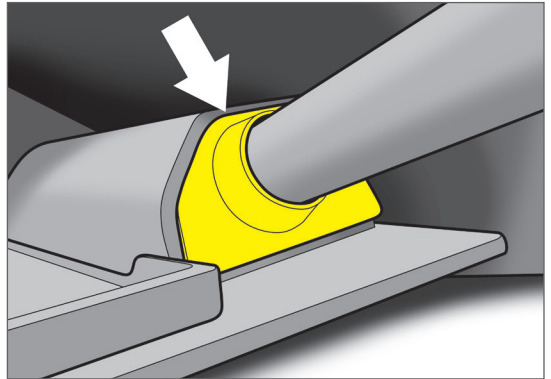
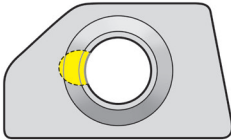

4. Run the turn signal harness down the steering column, through the rubber boot and behind the dash compartment.

NOTE: If a control box and/or flasher relay is already installed on the turn signal, remove them before running the wires into the dash.

5. Remove the jumper harness from the 9-pin turn signal connector on the plug and play harness. Retain jumper.

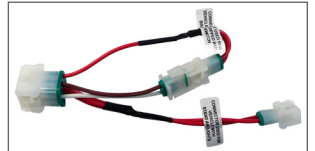

6. All Turn Signals: Connect the 9-pin connector on the turn signal to the 9-pin on the plug & play harness. Reconnect control box and/or flasher relay removed in Step 4.

High/ Low Beam Function (T3 only): Connect the bullet connector on the turn signal harness labeled "HI/LOW" to the corresponding bullet connector on the plug & play harness to enable the low beam function.

7. If installing the LGT-T3 turn signal, remove the push-pull switch from the 4-pin connector on the plug & play harness and replace it with the LGT-590 relay.



8. Push the rubber boot on the steering column back into place with the turn signal harness nested in the notch cut out in Step 3.

- Measure from the bottom of the turn signal to the dash. Using a utility knife, saw or tin snips, cut the LGT-107A (universal turn signal switch wire cover) to the measured length and sand rough edges.



- Snap the cover around the turn signal wires and the steering column. Secure any loose wires behind the dash.

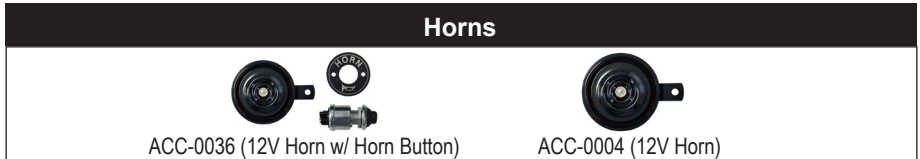

Horn Only (For use with LGT-T2, LGT-T3, LGT-T4 and LGT-T5 Turn Signals)

- Connect the spade connectors on the horn harness to the back of the horn on either terminal as shown below.

- Mount the horn under the driver side front end of the vehicle in a location free of moving parts using the Included Hardware. Use a pre-drilled hole or drill a 1/4" hole in a safe location on the golf cart frame. The horn should face away from the cart and its passengers.

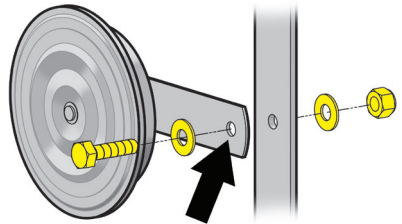

- Connect the triangular plug on the horn harness (LGT-147) to the triangular plug on the plug and play harness. Secure any loose wires with cable ties.

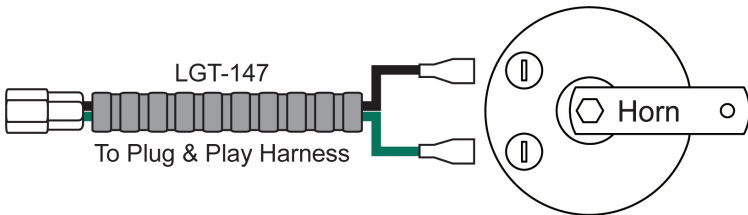

Horn w/ Horn Button (For use alone or with LGT-T1 Turn Signal)

- Mount the horn as shown above in Step 2.
- Find a convenient location on the floor to mount the horn button. This area should be free and clear of obstacles and wiring harnesses. Drill a 5/8" hole through the floor at the location. Cut away the floor mat over the hole.

3. Insert the horn button in the hole from the underside of the cart. Place the horn decal over the horn button. Screw the rubber button cover onto the horn button. Do not tighten.

4. Align the decal so it is straight. Mark the (2) hole locations for the decal onto the floor mat. Remove the horn button, cover and decal. Drill the (2) marked hole locations with a 7/32" bit.

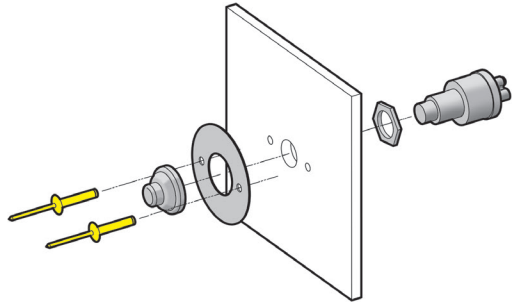

5. Install the horn button and decal as shown using the Included Rivets.

6. Connect the (2) ring terminals on the horn harness to the back of the horn button and connect the (2) spade terminals to the horn. You can connect the leads to either terminal.

7. Connect the triangular plug on the horn harness to the triangular plug on the plug and play harness. Secure any loose wires with cable ties.

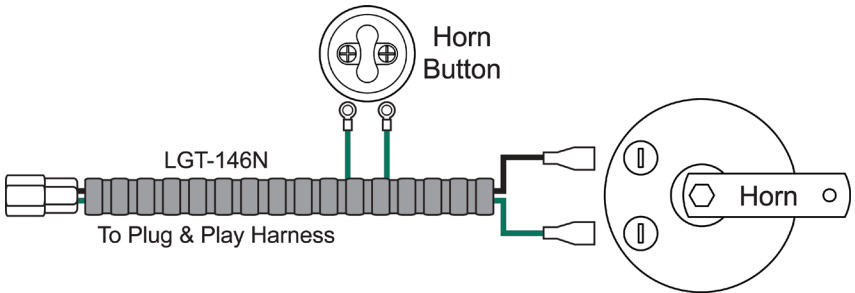

12 Volt Receptacle and Dual USB Outlets



ACC-0058



ACC-0097

CAUTION: 12V Outlets are designed for 12V operation ONLY unless otherwise stated. Operating at a voltage higher than 12V will damage accessories plugged into the outlet.

1. Find a convenient location on the dash or center compartment to mount the 12V receptacle and/or USB outlet.
2. Mark the center of the mounting location with a marking device.

ACC-0058 12 Volt Outlet

1. Drill a 1" hole at the marked location.

2. Insert the 12V receptacle into the hole and mount it with the Included Hardware.

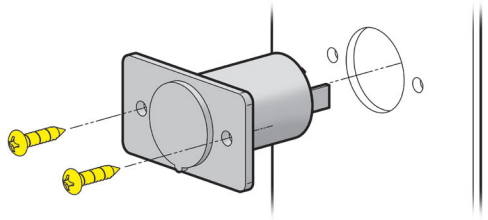

3. Connect the +/- 12V outlet leads on the light kit harness to the +/- 12V terminals on the back of ACC-0058.

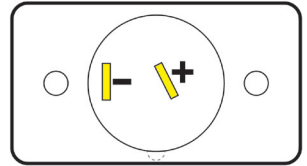

ACC-0097 Dual USB Outlet 12-48V

1. Drill a 1-1/8" hole (maximum size) at the marked location.
2. Insert the outlet through the protective cap and into the mounting area. Secure it with the retaining nut. Mount the flat panel cover over the outlet (not required) using the Included Screws.

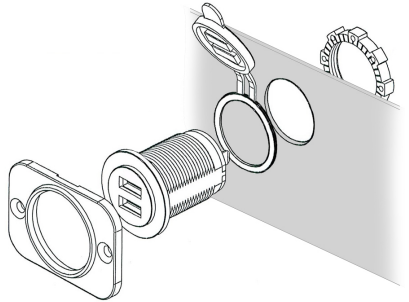

3. Connect the +/- 12V outlet leads on the light kit harness to the +/- 12V terminals on the back of the ACC-0097.

NOTE: A fuse holder (ACC-0019) and 15A fuse (ACC-0021) are recommended if direct connecting the USB receptacle to a battery source or voltage reducer.

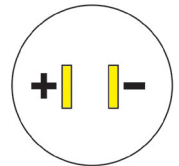

Brake Light Switches



LGT-B1 (12-48V)



LGT-B12 (12-48V)



LGT-B13 (12-48V)



LGT-B14 (12-48V)

All Brake Switches

1. Verify cart is in TOW position (if equipped), key is OFF and wheel is chocked.
2. If installing a brake switch without a turn signal, switch the (2) 2-pin male connectors on the jumper harness located on the turn signal connector. Leave the jumper on the harness.



3. Remove the rivets holding down the driver side floor mat and peel back the mat. Retain rivets for reuse.

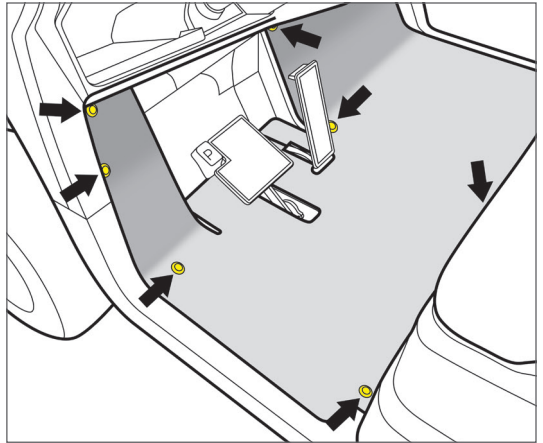

4. Remove the pedal cover using a flat head screwdriver to lift it off of the floor.

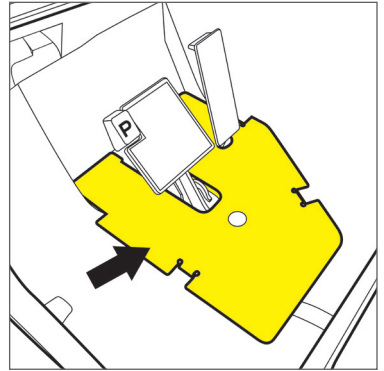

Brake Pad Light Switches (LGT-B1, LGT-B13 and LGT-B14)

LGT-B1 (LGT-138) Brake Pad Light Switch, Universal Fit

1. Lock the brake pedal and center the brake pad on the lower portion of the brake pedal assembly.
2. If mounting the switch using the Included Screws, fasten the pad directly to the pedal.

If mounting the switch using the Included Rivets, mark the hole locations and drill (6) 3/16" holes through the pedal. Mount the pad with the rivets.

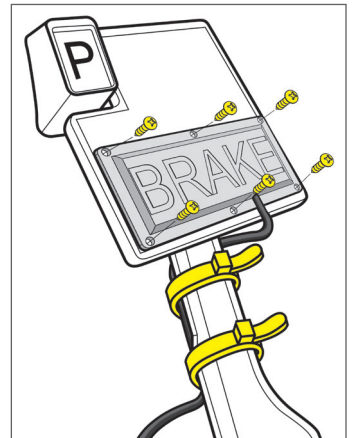

LGT-B13 Brake Pad Light Switch, OE Fit, Yamaha Drive2 17-19

LGT-B14 Brake Pad Light Switch, OE Fit, Yamaha Drive2 20+

1. Lock the brake pedal.
2. Install the brake pad by fitting it over the plate on the OE brake pedal.

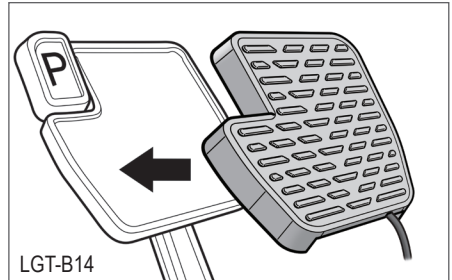
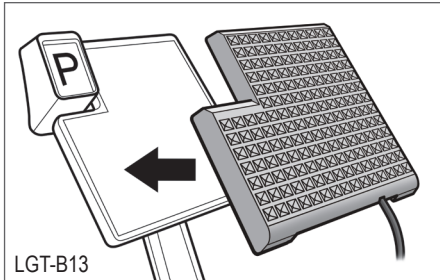

All Brake Pad Light Switches

1. With the brake pedal out of PARK, run the lead from the pad down the back side of the pedal and into the left side of the pedal compartment. Keep the wire close to the driver side so it does not get pinched.
2. Secure the brake pad lead to the pedal and cart's harness with a cable tie. Make sure the lead is free and clear of any moving parts so it does not get pinched. Slowly lower the pedal into PARK and recheck the lead. Readjust the cable ties if necessary.

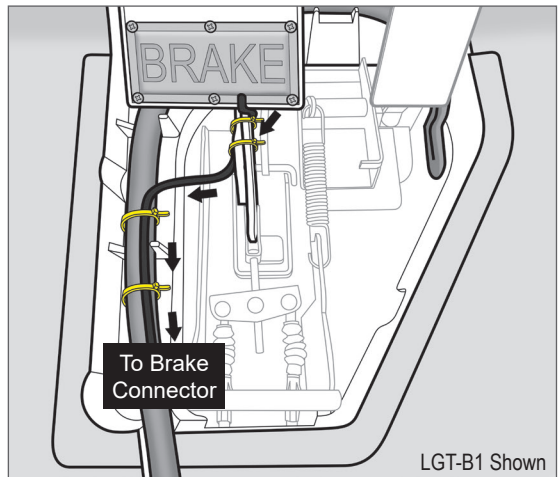

3. From under the pedal group, connect the brake pad lead to the triangular plug on the plug and play harness.

NOTE: Black ground wire is not used with the brake pad. The ground wire is only used with the time delay.

4. Use cable ties to secure the brake leads and harness close to the chassis and away from any moving parts.
5. Reinstall the pedal cover and floor mat with the Original Hardware.

LGT-B12 Linkage Activated Brake Switch with Time Delay

1. Remove the pin and cotter pin holding the brake cable assembly to the brake pedal. Discard.
2. Replace the original hardware with the Included Pin, Spacer(s) and Cotter Pin. Use spacers to fill gap between the cotter pin and the brake rod clevis.

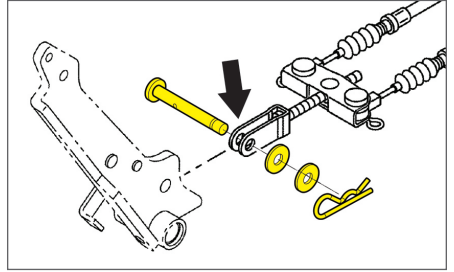
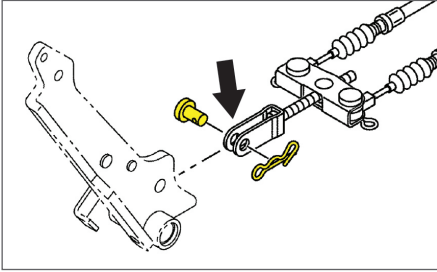

3. Mount the plunger to the brake bracket. Mount the bracket to the pedal group as shown using the included (1) 1/4-20 x 1" Hex Head Bolt, (2) Flat Washers and (1) Nylock Nut.

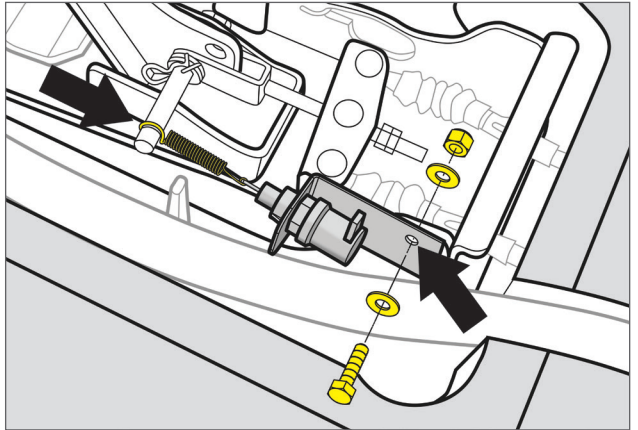

4. Connect the spring to the pin.

5. Locate an area on the side of the pedal compartment to mount the time delay. Drill a 1/4" hole at the location. Fasten the time delay to the pedal compartment using (1) 1/4-20 x 1" Hex Head Bolt and (1) Nylock Nut.

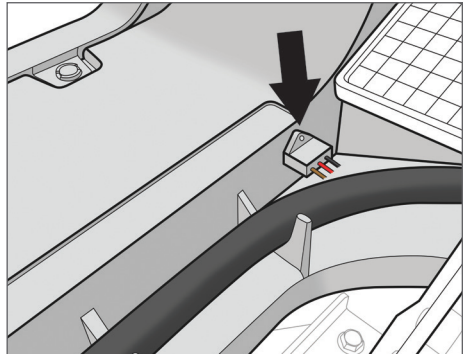

6. Connect the brake switch to the time delay and the light kit's harness as shown in the diagram to the right:

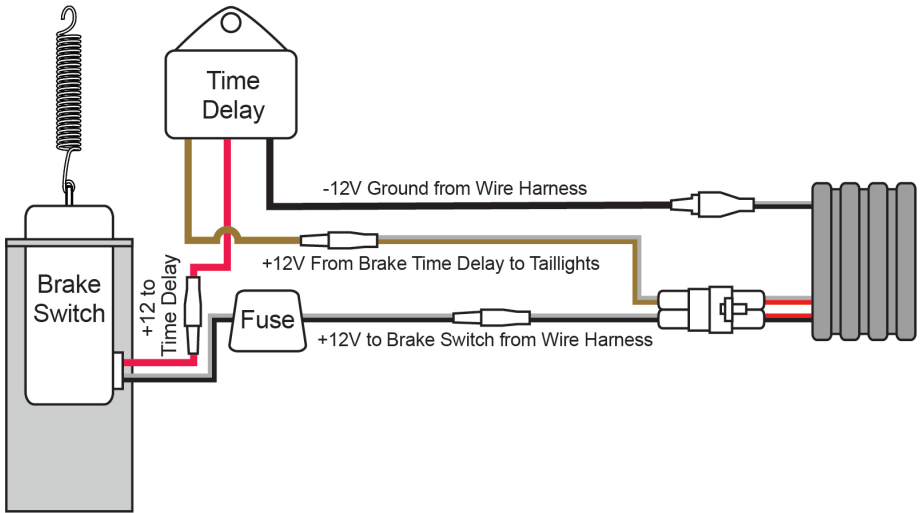

7. Secure all loose wires away from moving parts with cable ties.
8. Reinstall the pedal cover and floor mat using the Original Hardware.

Your Yamaha Drive2 Light Kit is now complete.
Please enjoy safely!

Scan QR code or use the link to view our installation video library.
<https://www.youtube.com/user/golfcartinstructions>



